

Some Application Hints for AP3406A

Prepared by Zhang Jiu Sheng
System Engineering Dept.

1. Introduction

The AP3406A is a 1.1MHz fixed frequency, current mode, PWM synchronous buck (step-down) DC-DC converter, capable of driving a 800mA load with high efficiency, excellent line and load regulation. The device integrates a main switch and a synchronous switch without an external Schottky diode. It is ideal for powering portable equipment that runs from a single Li-ion battery.

A standard series of inductors are available from several different manufacturers optimized for use with the AP3406A. This feature greatly simplifies the design of switch-mode power supplies.

This IC is available in TSOT-23-5 and MSOP-10 packages.

2. Operation

The AP3406A consists of a reference voltage, slope compensation circuit, error amplifier, PWM comparator, P-channel MOSFET (used as a main switch), N-channel MOSFET (used as a synchronous switch), current limit circuit, and others (see functional block diagram in Figure 1 for detailed information).

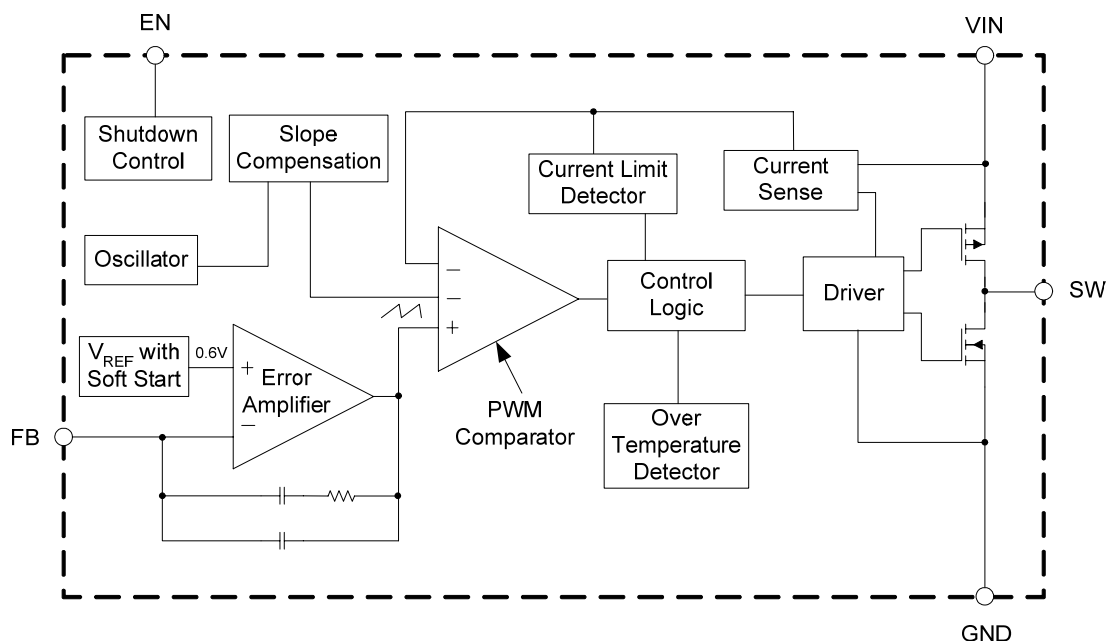

Figure 1. Functional Block Diagram of AP3406A

2.1 Main Loop Control

At the beginning of each cycle initiated by the clock signal (from the internal oscillator), the P-channel MOSFET switch is turned on, and the inductor current ramps up until the comparator trips and the control logic turns off the switch. The current limit comparator also turns off the switch in case the current limit of the P-channel MOSFET is exceeded. Then the N-channel synchronous switch is turned on and the inductor current ramps down. The next cycle

is initiated by the clock signal again, turning off the N-channel synchronous switch and turning on the P-channel switch. (See Figure 2)

2.2 Dropout Operation

As the input supply voltage decreases to a value approaching the output voltage, the duty cycle increases to the maximum. Further reduction of the supply voltage forces the P-channel main switch to

remain on for more than one cycle until it reaches 100% duty cycle. The output voltage will then be determined by the input voltage minus the voltage drop across the P-channel MOSFET and the inductor. This is particularly useful in battery powered applications to achieve longest operation time by taking full advantage of the whole battery voltage range.

2.3 Short Circuit Protection

When the output is shorted to ground, the frequency of the oscillator is reduced to 600 kHz, which ensures that the inductor current has more time to decay, thereby preventing damage. The frequency of the oscillator will gradually increase to 1.1MHz when feedback voltage gradually increase from 0V to 0.6V.

2.4 Soft Start

The AP3406A has an internal soft start circuit that limits the inrush current during start-up. The soft start feature allows the converter output to gradually reach

the initial steady-state output voltage, thereby reducing start-up stresses and current surges.

2.5 UVLO

If UVLO threshold is not met, all functions of AP3406A are disabled. The UVLO circuit prevents the device from misoperation at low input voltage. It prevents the converter from turning on the main switch and synchronous switch under undefined condition.

2.6 Thermal Protection

If the thermal protection circuit senses the junction temperature exceeding approximately 160°C, the thermal shutdown circuit will turn off the main switch and synchronous switch. The thermal hysteresis is about 30°C, which means that the converter can return to normal operation when the junction temperature drops below 130°C. It prevents the converter from thermal damage under some unexpected condition.

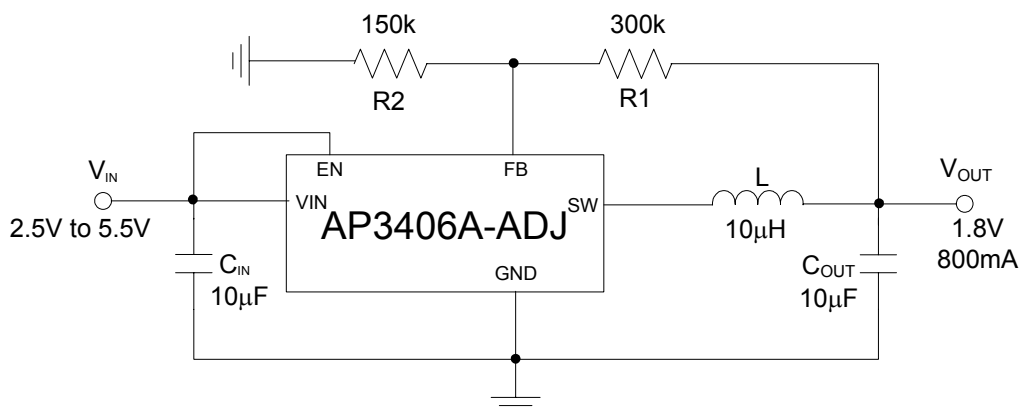

Figure 2. Typical Application of AP3406A

3. Component Select Guide (See Figure 2)

3.1 Input Capacitor

The input current of the buck converter is discontinuous, so a bulk capacitor is required to keep the DC input voltage constant. To ensure a stable operation, the capacitor should be placed as close to the VIN pin as possible. The value of the input capacitor will vary according to different load and input voltage source impedance characteristics. The typical value is about 10µF.

Care must be taken when ceramic capacitor is used

at the input. When a ceramic capacitor is used at the input and the power is supplied by a wall adapter through long wires, a load step at the output can induce ringing at the input, and this ringing can couple to the output and be mistaken as loop stability. The X5R or X7R ceramic capacitors have the best temperature and voltage characteristics, which is good for input capacitor.

3.2 Output Capacitor

The output capacitor is the most critical component of a switching regulator, it is used for output filtering and keeping the loop stable. The typical value is 10µF.

The primary parameters for output capacitor are the voltage rating and the equivalent series resistance (ESR). The ESR value has relation to the voltage rating. For the same product series, the capacitor with higher voltage rating will have smaller ESR value. A low ESR capacitor is preferred to keep the output voltage ripple low. The output ripple is calculated as the following:

$$\Delta V_{OUT} \approx \Delta I_L * (ESR + \frac{1}{8 * f * C_{OUT}})$$

Where f is the switching frequency, C_{OUT} is the output capacitance and ΔI_L is the ripple current in the inductor.

3.3 Inductor

The inductor is used to supply smooth current to output when it is driven by a switching voltage. The higher the inductance, the lower the peak-to-peak ripple current, as the higher inductance usually means the larger inductor size, so some trade-offs should be made when select an inductor. The AP3406A is a synchronous buck converter. It always works on continuous current mode (CCM), and the inductor value can be selected as the following:

$$L = V_{OUT} * \frac{V_{IN} - V_{OUT}}{f * V_{IN} * I_{OUT} * k}$$

Where V_{OUT} is the output voltage, V_{IN} is the input voltage, I_{OUT} is the output current, k is the coefficient about ripple current, the typical value is 20% to 40%.

Another important parameter for the inductor is the current rating. Exceeding an inductor's maximum current rating may cause the inductor to saturate and overheat. If inductor value has been selected, the peak inductor current can be calculated as the following:

$$I_{PEAK} = I_{OUT} + V_{OUT} * \frac{V_{IN} - V_{OUT}}{2 * f * V_{IN} * L}$$

It should be ensured that the current rating of the selected inductor is 1.5 times of the I_{PEAK} .

3.4 Feedback Divider Resistors

The output voltage is set by the feedback divider resistors (see Figure 3) according to the following formula:

$$V_{OUT} = 0.6 * (1 + \frac{R1}{R2})$$

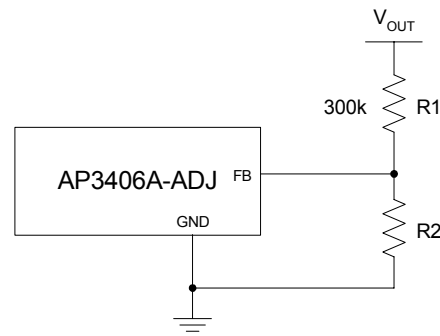

Figure 3

The resistor R1 also sets the feedback loop bandwidth with the internal compensation capacitor, so choose R1 around 300k for optimal transient response. Then, solve for R2:

$$R2 = \frac{R1}{\frac{V_{OUT}}{0.6} - 1}$$

4. Layout Consideration

PCB layout is very important to the performance of AP3406A. The loop which switching current flows through should be kept as short as possible. The external components (especially C_{IN}) should be placed as close to the IC as possible. Special attention should be paid to below 2 items:

4.1 The Route of The Feedback Wiring

Try to route the feedback trace as far from the inductor and noisy power traces as possible. You would also like the feedback trace to be as direct as possible and somewhat thick. These two sometimes involve a trade-off, but keeping it away from inductor and other noise sources is the more critical of the two. Locate the feedback divider resistor network near the feedback pin with short leads.

4.2 The GND and PGND Connection for MSOP-10 Package

The AP3406A uses 2 separate ground connections for MSOP-10 package: PGND for driver, NMOS power device and GND for sensitive analog control circuitry. For better performance, GND and PGND should be tied as closely as possible.

Figure 4 and 5 are examples of PCB layout for TSOT-23-5 and MSOP-10 packages respectively.

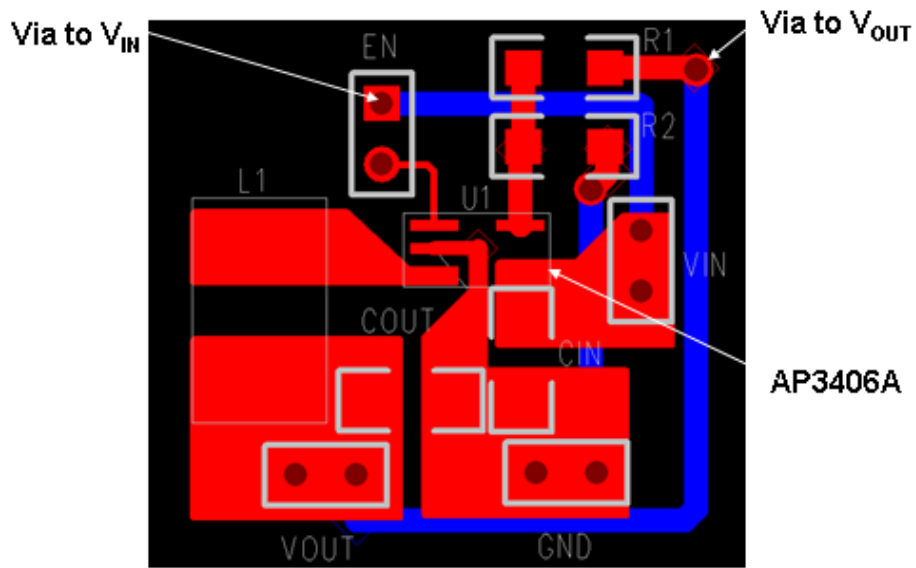

Figure 4

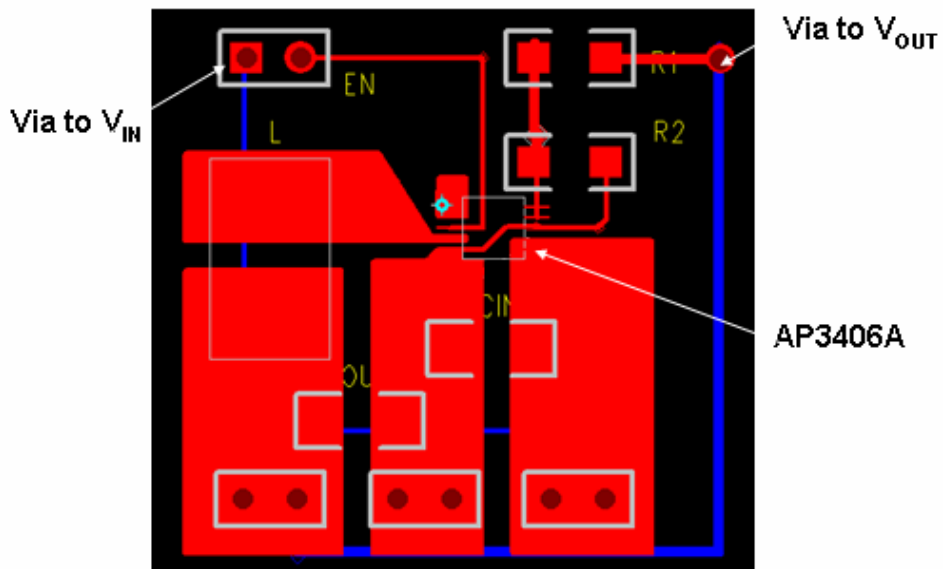

Figure 5