

DESCRIPTION

The AP62600 is a 6A, synchronous buck converter with a wide input voltage range of 4.5V to 18V. The device fully integrates a 36mΩ high-side power MOSFET and a 14mΩ low-side power MOSFET to provide high-efficiency step-down DC-DC conversion.

The AP62600 is easily used by minimizing the external component count due to its adoption of Constant On-Time (COT) control to achieve fast transient response, easy loop stabilization, and low output voltage ripple.

The AP62600 design is optimized for Electromagnetic Interference (EMI) reduction. The device has a proprietary gate driver scheme to resist switching node ringing without sacrificing MOSFET turn-on and turn-off times, which reduces high-frequency radiated EMI noise caused by MOSFET switching.

The device is available in the V-QFN2030-12 (Type A) package.

FEATURES

- VIN: 4.5V to 18V
- Output Voltage (VOUT): 0.6V to 7V
- 6A Continuous Output Current
- 0.6V ± 1% Reference Voltage
- 360µA Quiescent Current
- Selectable Operation Modes
 - Pulse Frequency Modulation (PFM)
 - Ultrasonic Mode (USM)
 - Pulse Width Modulation (PWM)
- Selectable Switching Frequency
 - 400kHz
 - 800kHz
 - 1.2MHz
- Programmable Soft-Start Time
- Proprietary Gate Driver Design for Best EMI Reduction
- Power-Good Indicator
- Precision Enable Threshold to Adjust UVLO
- Protection Circuitry
 - Undervoltage Lockout (UVLO)
 - Cycle-by-Cycle Valley Current Limit
 - Thermal Shutdown

APPLICATIONS

- 5V and 12V Input Distributed Power Bus Supplies
- Television Sets and Monitors
- White Goods and Small Home Appliances
- FPGA, DSP, and ASIC Supplies
- Home Audio
- Network Systems
- Gaming Consoles
- Consumer Electronics
- General Purpose Point of Load

FUNCTIONAL BLOCK

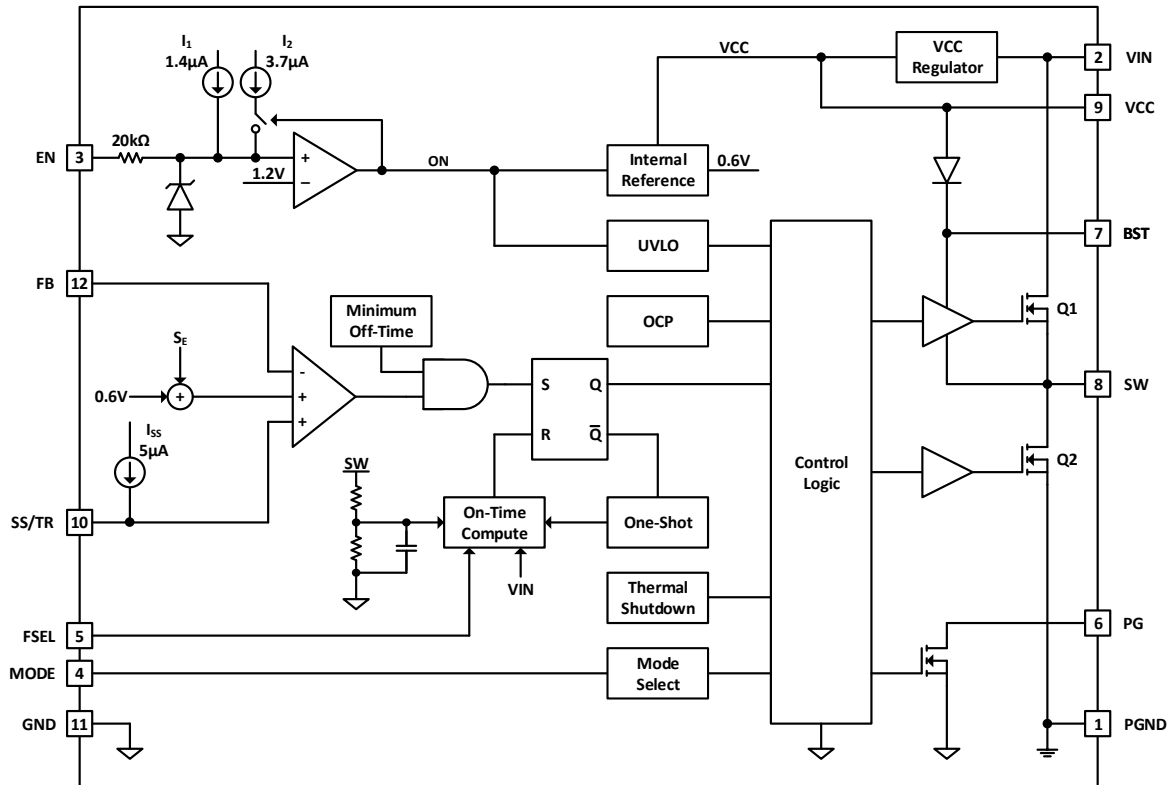

Figure 1. Functional Block Diagram

ABSOLUTE MAXIMUM RATINGS

Symbol	Parameter	Rating	Unit
VIN	Supply Pin Voltage	-0.3 to +20.0 (DC)	V
		-0.3 to 22.0 (400ms)	
VCC	VCC Pin Voltage	-0.3V to +6.0	V
V _{EN}	Enable/UVLO Pin Voltage	-0.3V to +6.0	V
V _{MODE}	MODE Select Pin Voltage	-0.3V to +6.0	V
V _{FSEL}	Frequency Select Pin Voltage	-0.3V to +6.0	V
V _{PG}	Power-Good Pin Voltage	-0.3V to +6.0	V
V _{BST}	Bootstrap Pin Voltage	V _{SW} - 0.3 to V _{SW} + 6.0	V
V _{SW}	Switch Pin Voltage	-1.0 to VIN + 0.3 (DC)	V
		-2.5 to VIN + 2.0 (20ns)	
V _{SS/TR}	Soft-Start/Tracking Pin Voltage	-0.3V to +6.0	V
V _{FB}	Feedback Pin Voltage	-0.3V to +6.0	V
T _{ST}	Storage Temperature	-65 to +150	°C
T _J	Junction Temperature	+150	°C
T _L	Lead Temperature	+260	°C
ESD Susceptibility			
HBM	Human Body Mode	±2000	V
CDM	Charge Device Model	±500	V

RECOMMENDED OPERATING CONDITIONS

Symbol	Parameter	Min	Max	Unit
V _{IN}	Supply Voltage	4.5	18.0	V
V _{OUT}	Output Voltage	0.6	7.0	V
T _A	Operating Ambient Temperature	-40	+85	°C
T _J	Operating Junction Temperature	-40	+125	°C

EVALUATION BOARD

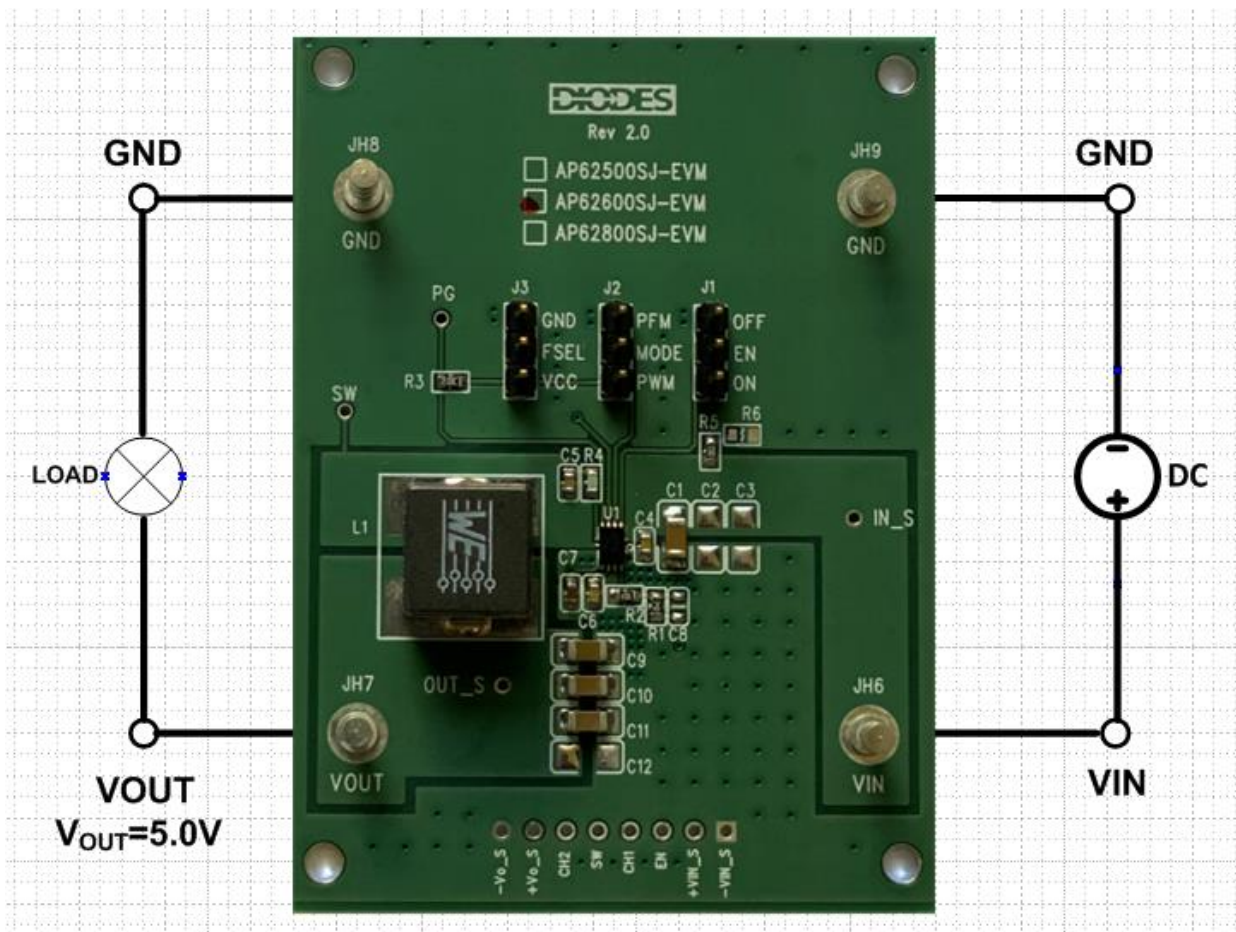

Figure 2. AP62600SJ-EVM

QUICK START GUIDE

The AP62600SJ-EVM has a simple layout and allows access to the appropriate signals through test points. The board is targeted to be used in providing a simple and convenient evaluation environment for the AP62600.

To operate the EVM, set jumpers J1, J2 and J3 to the desired positions per below shown:

- J1 = EN pin input jumper. For Enable, to enable IC, leave it OPEN or jump to “ON” to program an external resistor voltage divider at R5 and R6 to set the EN level. Jump to “OFF” position to disable IC.
- J2 = PFM, PWM or USM mode selection. At J2, connect a jumper to PWM to force the device in Pulse Width Modulation (PWM) operation mode. Connect a jumper to PFM to ground the pin to operate the device in Pulse Frequency Modulation (PFM) operation mode without Ultrasonic Mode (USM). Leave J2 OPEN to float the pin to operate the device in PFM with USM mode.
- J3 = Switching frequency selection. At J3, connect a jumper to GND to set clock frequency to 400kHz. Leave J3 OPEN to float the pin to set clock frequency to 800kHz. Connect a jumper to VCC to set clock frequency to 1.2MHz.

To evaluate the performance of the AP62600SJ-EVM, follow the procedure below:

1. Connect a power supply to the input terminals V_{IN} and GND. Set V_{IN} to 12V.
2. Connect the positive terminal of the electronic load to V_{OUT} and negative terminal to GND.
3. By default, the evaluation board should now power up with a 5.0V output voltage. Frequency is 800kHz.
4. Check for the proper output voltage of 5.0V ($\pm 1\%$) at the output terminals V_{OUT} and GND. Measurement can also be done with a multimeter with the positive and negative leads between V_{OUT} and GND.
5. Set the load to 6A through the electronic load. Check for the stable operation of the SW signal on the oscilloscope. Measure the switching frequency.

MEASUREMENT/PERFORMANCE GUIDELINES:

- 1) When measuring the output voltage ripple, maintain the shortest possible ground lengths on the oscilloscope probe. Long ground leads can erroneously inject high-frequency noise into the measured ripple.
- 2) For efficiency measurements, connect an ammeter in series with the input supply to measure the input current. Connect an electronic load to the output for output current.

APPLICATION INFORMATION

Setting the Output Voltage of AP62600

(1) Setting the output voltage

The AP62600 features external programmable output voltage by using a resistor divider network R2 and R1 as shown in the typical application circuit. The output voltage is calculated as below,

$$R1 = R2 \cdot \left(\frac{V_{OUT}}{0.6V} - 1 \right)$$

First, select a value for R1 according to the value recommended in the table 1. Then, R3 is determined. The output voltage is given by Table 1 for reference. For accurate output voltage, 1% tolerance is required.

Vo	R2	R1
1.2V	10KΩ	10KΩ
1.5V	10KΩ	15.0KΩ
1.8V	10KΩ	20.0KΩ
2.5V	10KΩ	31.6KΩ
3.3V	10KΩ	45.3KΩ
5V	10KΩ	73.2KΩ

Table 1. Resistor selection for output voltage setting

EXTERNAL COMPONENT SELECTION:

1) Input & output Capacitors:

- (1) For lower output ripple, low ESR is required.
- (2) For low leakage current, X6S/X7R ceramic capacitors are recommend for multiple parallel connection.
- (3) The C1-3 are the input capacitors of supply input pins (capacitances > 22μF).
- (4) The C7 is the input capacitor of VCC pin (capacitance ≥ 1μF).
- (5) The C9-11 are output capacitors, recommended in Table 2.

2) Bootstrap Voltage Regulator:

An external 0.1μF ceramic capacitor is required as bootstrap capacitor between BST and SW pin to work as high side power MOSFET gate driver

3) Soft-start time control capacitor:

C6 controls the soft-start time of the output voltage. It can be changed for a shorter or slower ramp up of Vout. The capacitor along with an internal ISS of 5μA, sets the soft-start interval of the converter, TSS, according to equation below:

$$C_{SS} \text{ (nF)} = 8.33 \cdot T_{SS} \text{ (ms)}$$

4) Inductor (L):

- (1) Low DCR for good efficiency
- (2) Inductance saturate current must higher than the output current
- (3) The recommended inductance is shown in the table 2 below.

Frequency	Output Voltage	1.05V	1.2V	1.8V	2.5 V	3.3 V	5.0 V
400KHz	Output Capacitor	88 μ F	66 μ F	66 μ F	66 μ F	66 μ F	66 μ F
	Inductor	3.3 μ H	3.3 μ H	3.3 μ H	3.3 μ H	4.7 μ H	4.7 μ H
	Würth PART	7443330330	7443330330	7443330330	7443330330	7443330470	7443330470
800 KHz	Output Capacitor	44 μ F	66 μ F	66 μ F	66 μ F	66 μ F	66 μ F
	Inductor	1.0 μ H	1.0 μ H	1.0 μ H	1.0 μ H	1.0 μ H	1.5 μ H
	Würth PART	7443330100	7443330100	7443330100	7443330100	7443330100	7443330150
1.2MHz	Output Capacitor	66 μ F	66 μ F	66 μ F	66 μ F	66 μ F	66 μ F
	Inductor	0.47 μ H	0.47 μ H	0.68 μ H	0.68 μ H	0.82 μ H	1.0 μ H
	Würth PART	7443330047	7443330047	7443330068	7443330068	7443330082	7443330100

Table 2. Recommended inductors and output capacitor

EVALUATION BOARD SCHEMATIC

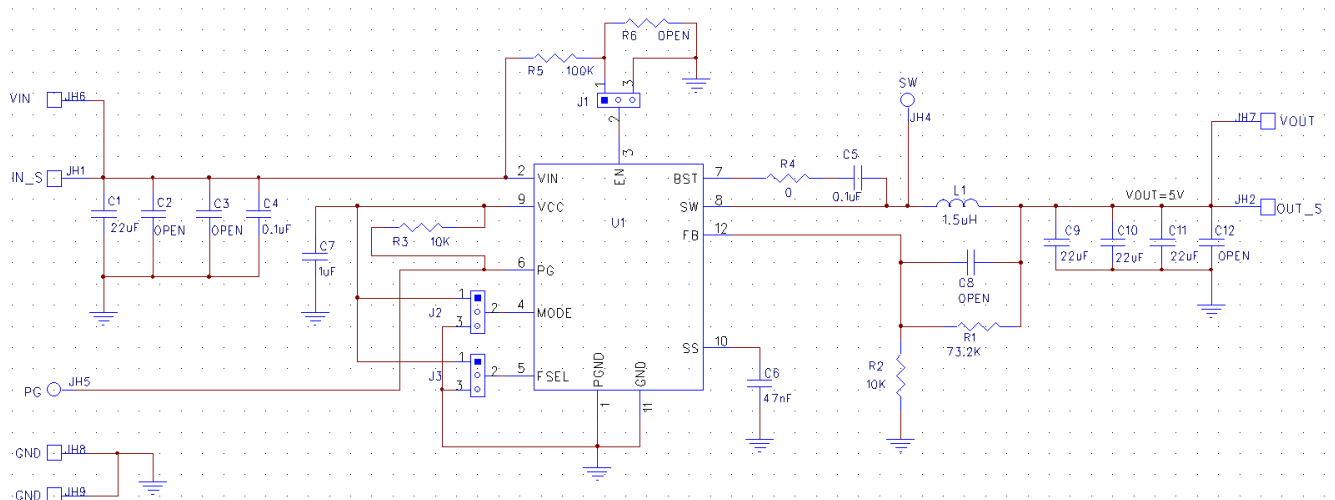

Figure 3. AP2600SJ-EVM Schematic

PCB TOP LAYOUT

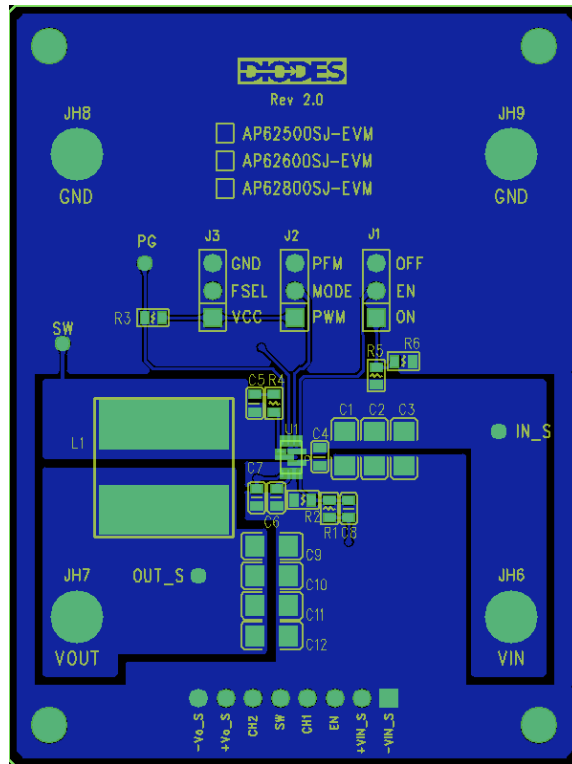

Figure 4. AP62600SJ-EVM – Top Layer

PCB BOTTOM LAYOUT

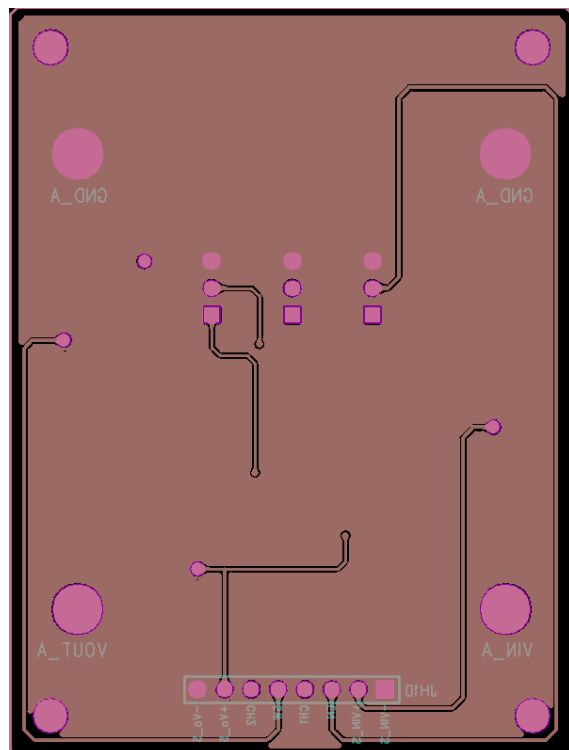

Figure 5. AP62600SJ-EVM – Bottom Layer

BILL OF MATERIALS for AP62600SJ-EVM for $V_{OUT}=5V$

Ref	Value	Description	Qty	Size	Vendor	Manufacturer PN
C1, C9, C10, C11	22 μ F	Ceramic Capacitor, 25V, X6S	4	1206	Samsung	CL31X226KAHN3NE
C4, C5	0.1 μ F	Ceramic Capacitor, 50V, X7R, 10%	2	0603	Würth Electronics	885012206095
C6	47nF	Ceramic Capacitor, 50V, X7R, 10%	1	0603	Würth Electronics	885012206093
C7	1 μ F	Ceramic Capacitor, 25V, X7R, 10%	1	0603	Würth Electronics	885012206076
L1	1.5 μ H	DCR=2.5m Ω , I _r =18A	1	10.9x10x 9.7mm	Würth Electronics	7443330150
R1	73.2K Ω	RES SMD 1%	1	0603	Panasonic	ERJ-3EKF7322V
R2	10K Ω	RES SMD 1%	1	0603	Panasonic	ERJ-3EKF1002V
R3	10K Ω	RES SMD 1%	1	0603	Yageo	RC0603FR-0710KL
R4	0 Ω	RES SMD 1%	1	0603	Vishay	MCT06030Z0000ZP5 00
J1, J2, J3		PCB Header, 40 POS	3	1X3	3M	2340-6111TG
JH6, JH7, JH8, JH9	1598	Terminal Turret Triple 0.094" L (Test Points)	4	Through- Hole	Keystone Electronics	1598-2
U1	AP62600	6A Sync DC/DC Converter	1	QFN2030-12	Diodes Incorporated	AP62600SJ

TYPICAL PERFORMANCE CHARACTERISTICS

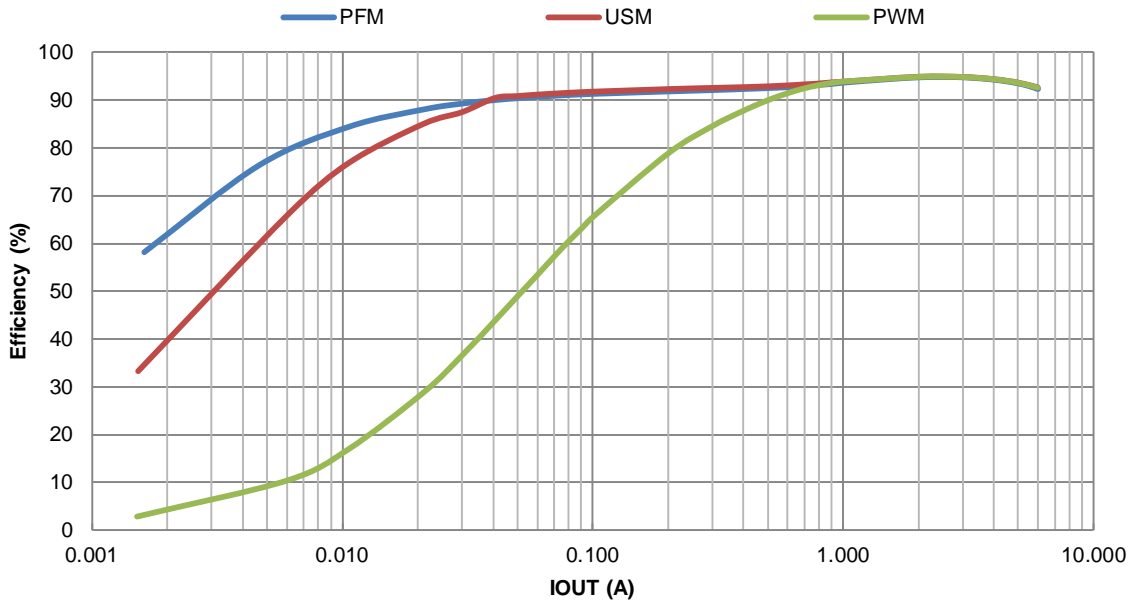

Figure 6. Efficiency vs. Output Current, VIN = 12V, VOUT = 5V, L = 1.5µH, fsw = 800kHz

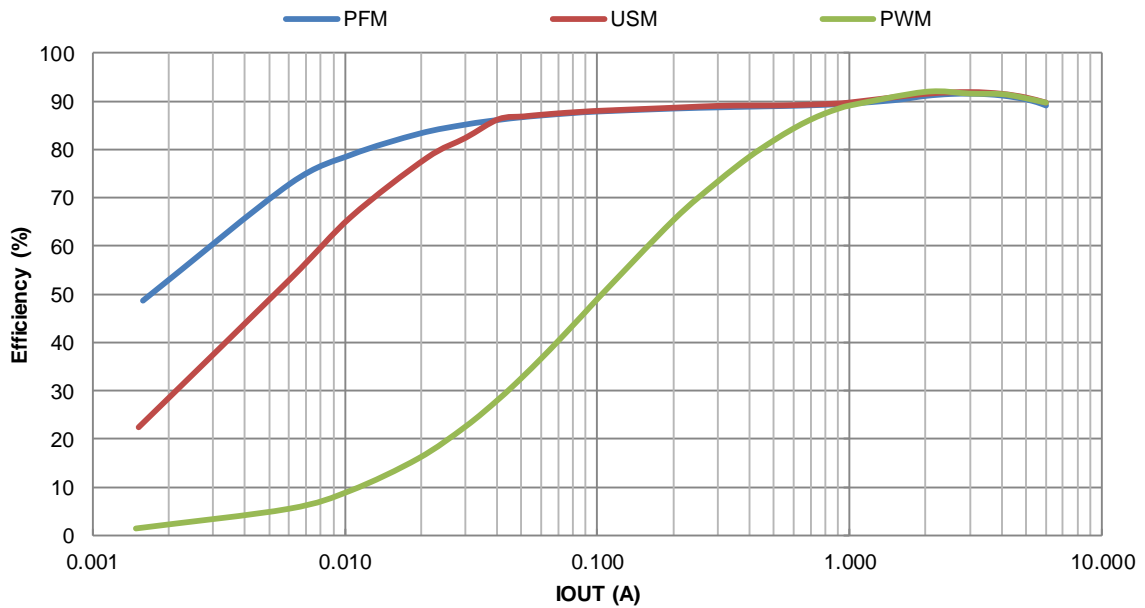
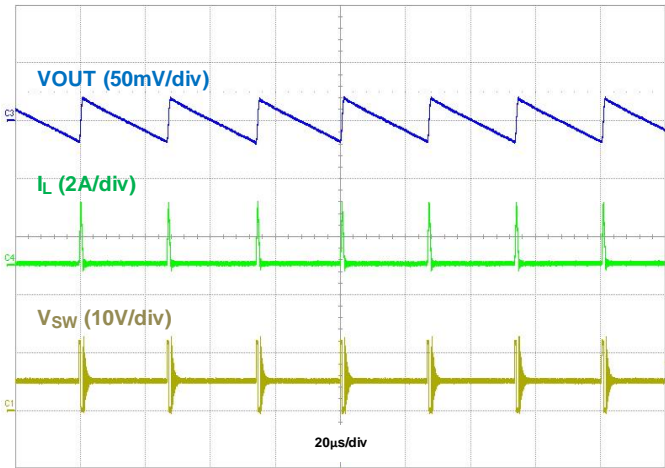
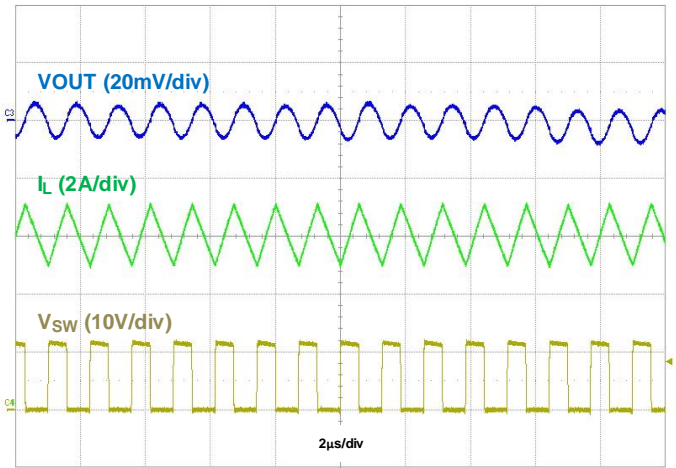

Figure 7. Efficiency vs. Output Current, VIN = 12V, VOUT = 3.3V, L = 1.2µH, fsw = 800kHz



**Figure 8. Output Voltage Ripple, IOU = 50mA
VIN = 12V, VOUT = 5V PFM f_{SW} = 800kHz**



**Figure 9. Output Voltage Ripple, IOU = 6A
VIN = 12V, VOUT = 5V PFM f_{SW} = 800kHz**

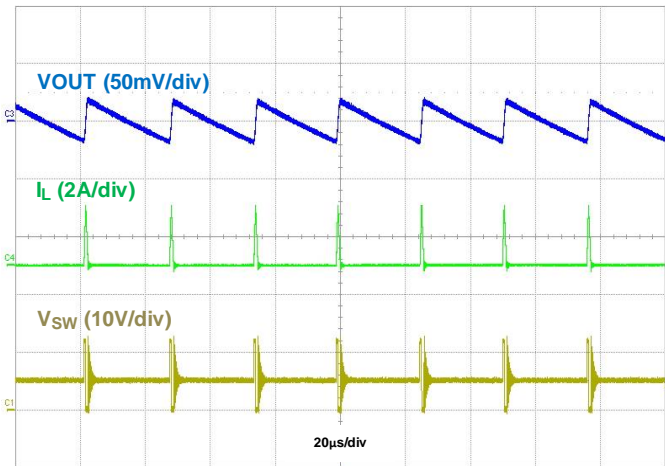

**Figure 10. Output Voltage Ripple, IOU = 50mA
VIN = 12V, VOUT = 5V USM f_{SW} = 800kHz**

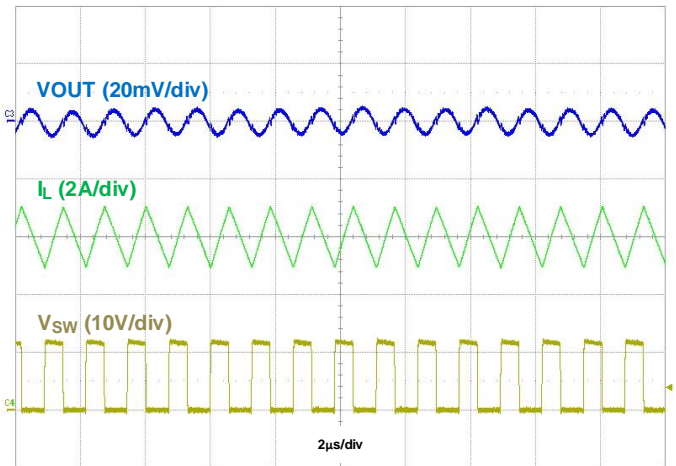

**Figure 11. Output Voltage Ripple, IOU = 6A
VIN = 12V, VOUT = 5V USM f_{SW} = 800kHz**

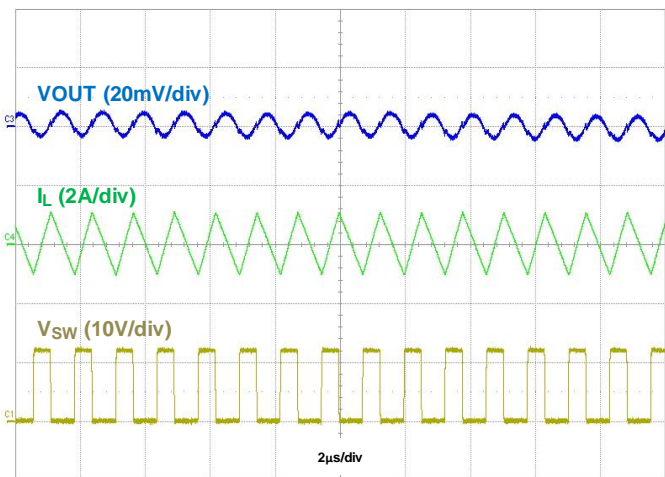

**Figure 12. Output Voltage Ripple, IOU = 50mA
VIN = 12V, VOUT = 5V PWM f_{SW} = 800kHz**

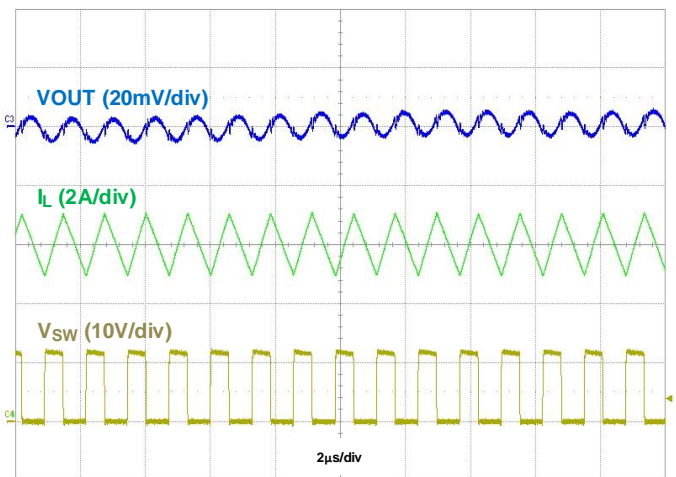

**Figure 13. Output Voltage Ripple, IOU = 6A
VIN = 12V, VOUT = 5V PWM f_{SW} = 800kHz**

IMPORTANT NOTICE

1. DIODES INCORPORATED (Diodes) AND ITS SUBSIDIARIES MAKE NO WARRANTY OF ANY KIND, EXPRESS OR IMPLIED, WITH REGARDS TO ANY INFORMATION CONTAINED IN THIS DOCUMENT, INCLUDING, BUT NOT LIMITED TO, THE IMPLIED WARRANTIES OF MERCHANTABILITY, FITNESS FOR A PARTICULAR PURPOSE OR NON-INFRINGEMENT OF THIRD PARTY INTELLECTUAL PROPERTY RIGHTS (AND THEIR EQUIVALENTS UNDER THE LAWS OF ANY JURISDICTION).
2. The Information contained herein is for informational purpose only and is provided only to illustrate the operation of Diodes' products described herein and application examples. Diodes does not assume any liability arising out of the application or use of this document or any product described herein. This document is intended for skilled and technically trained engineering customers and users who design with Diodes' products. Diodes' products may be used to facilitate safety-related applications; however, in all instances customers and users are responsible for (a) selecting the appropriate Diodes products for their applications, (b) evaluating the suitability of Diodes' products for their intended applications, (c) ensuring their applications, which incorporate Diodes' products, comply the applicable legal and regulatory requirements as well as safety and functional-safety related standards, and (d) ensuring they design with appropriate safeguards (including testing, validation, quality control techniques, redundancy, malfunction prevention, and appropriate treatment for aging degradation) to minimize the risks associated with their applications.
3. Diodes assumes no liability for any application-related information, support, assistance or feedback that may be provided by Diodes from time to time. Any customer or user of this document or products described herein will assume all risks and liabilities associated with such use, and will hold Diodes and all companies whose products are represented herein or on Diodes' websites, harmless against all damages and liabilities.
4. Products described herein may be covered by one or more United States, international or foreign patents and pending patent applications. Product names and markings noted herein may also be covered by one or more United States, international or foreign trademarks and trademark applications. Diodes does not convey any license under any of its intellectual property rights or the rights of any third parties (including third parties whose products and services may be described in this document or on Diodes' website) under this document.
5. Diodes' products are provided subject to Diodes' Standard Terms and Conditions of Sale (<https://www.diodes.com/about/company/terms-and-conditions/terms-and-conditions-of-sales/>) or other applicable terms. This document does not alter or expand the applicable warranties provided by Diodes. Diodes does not warrant or accept any liability whatsoever in respect of any products purchased through unauthorized sales channel.
6. Diodes' products and technology may not be used for or incorporated into any products or systems whose manufacture, use or sale is prohibited under any applicable laws and regulations. Should customers or users use Diodes' products in contravention of any applicable laws or regulations, or for any unintended or unauthorized application, customers and users will (a) be solely responsible for any damages, losses or penalties arising in connection therewith or as a result thereof, and (b) indemnify and hold Diodes and its representatives and agents harmless against any and all claims, damages, expenses, and attorney fees arising out of, directly or indirectly, any claim relating to any noncompliance with the applicable laws and regulations, as well as any unintended or unauthorized application.
7. While efforts have been made to ensure the information contained in this document is accurate, complete and current, it may contain technical inaccuracies, omissions and typographical errors. Diodes does not warrant that information contained in this document is error-free and Diodes is under no obligation to update or otherwise correct this information. Notwithstanding the foregoing, Diodes reserves the right to make modifications, enhancements, improvements, corrections or other changes without further notice to this document and any product described herein. This document is written in English but may be translated into multiple languages for reference. Only the English version of this document is the final and determinative format released by Diodes.
8. Any unauthorized copying, modification, distribution, transmission, display or other use of this document (or any portion hereof) is prohibited. Diodes assumes no responsibility for any losses incurred by the customers or users or any third parties arising from any such unauthorized use.
9. This Notice may be periodically updated with the most recent version available at <https://www.diodes.com/about/company/terms-and-conditions/important-notice>

The Diodes logo is a registered trademark of Diodes Incorporated in the United States and other countries.
All other trademarks are the property of their respective owners.
© 2023 Diodes Incorporated. All Rights Reserved.

www.diodes.com