

Application Note

AP7354D Application Information and Demo Board User Guide

Description

The AP7354 is a low dropout regulator with high output voltage accuracy. The AP7354 includes a voltage reference, error amplifier, current limit circuit, and an enable input to turn it on/off. With the integrated resistor network, fixed output voltage versions can be delivered.

With its ultra-low quiescent current, the AP7354 is well-suited for lowpower handheld, wearable devices, and other battery-operated devices requiring an extended time period until new battery replacement.

Features

- Wide V_{IN} Range: 2.0V to 5.5V
- Guarantee Output Current: 150mA
- Output Voltage Range: 1.1V to 4.5V
- V_{OUT} Accuracy: $\pm 1\%$
- Quiescent Current as Low as 0.25 μ A
- Output Discharge Available for Devices in SOT25 or X2- DFN1010-4 (Type B)
- Typical Standby Current: 0.02 μ A
- ESD Protection Exceeds JESD 22
 - Exceeds 4000V Human Body Model (A114)
 - Exceeds 400V Machine Model (A115)
- Latch-Up Exceeds 400mA per JESD 78, Class I

- Totally Lead-Free & Fully RoHS Compliant (Notes 1 & 2)
- Halogen and Antimony Free. "Green" Device (Note 3)
- For automotive applications requiring specific change control (i.e. parts qualified to AEC-Q100/101/200, PPAP capable, and manufactured in IATF 16949 certified facilities) ,please contact us or your local Diodes representative.
<https://www.diodes.com/quality/product-definitions/>

Applications

- Wearable Electronics
- Sensor Module for Internet-of-Things (IoT)
- Wireless Communication Module
- Battery-Operated Device Printers
- Camera

Notes: 1. No purposely added lead. Fully EU Directive 2002/95/EC (RoHS) & 2011/65/EU (RoHS 2) compliant.
2. See http://www.diodes.com/quality/lead_free.html for more information about Diodes Incorporated's definitions of Halogen- and Antimony-free, "Green" and Lead-free.
3. Halogen- and Antimony-free "Green" products are defined as those which contain <900ppm bromine, <900ppm chlorine (<1500ppm total Br + Cl) and <1000ppm antimony compounds

Application Note

AP7354D Application Information and Demo Board User Guide

Typical Applications Circuit

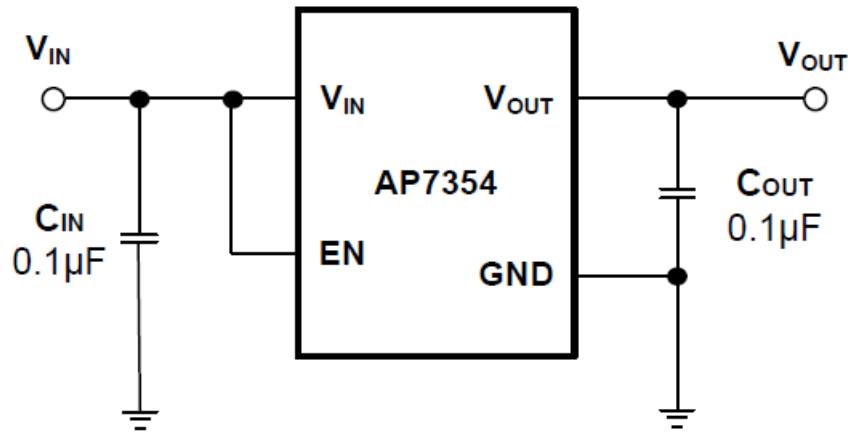

X5R- and X7R-type capacitors are suggested due to their minimal variation in value and ESR over temperature.

Absolute Maximum Ratings

Symbol	Parameter	Ratings	Unit
ESD HBM	Human Body Model ESD Protection	4	kV
ESD MM	Machine Model ESD Protection	400	V
VIN	Input Voltage	6.0	V
VEN	Input Voltage at EN Pin	6.0	V
VOUT	Output Voltage to GND	-0.3 to VIN +0.3	V
TA	Operating Ambient Temperature	-40 to +85	°C
TJ	Maximum Junction Temperature	+125	°C
TSTG	Storage Temperature	-55 to +125	°C
PD	Power Dissipation	315	mW

This application note contains new product information. Diodes, Inc. reserves the right to modify the product specification without notice. No liability is assumed as a result of the use of this product. No rights under any patent accompany the sale of the product.

Application Note

AP7354D Application Information and Demo Board User Guide

Recommended Operating Conditions

Symbol	Parameter	Min	Max	Unit
V_{IN}	Input Voltage	2.0	5.5	V
I_{OUT}	Output Current	0	150	mA
T_A	Operating Ambient Temperature	-40	+85	°C

Evaluation Board



This application note contains new product information. Diodes, Inc. reserves the right to modify the product specification without notice. No liability is assumed as a result of the use of this product. No rights under any patent accompany the sale of the product.

Application Note

AP7354D Application Information and Demo Board User Guide

Quick Start Guide

The AP7354D-EVM has a simple layout and allows access to the appropriate signals through test points. To evaluate the performance of the AP7354D, follow the procedure below:

1. Connect a power supply to the input terminals VIN and GND. Set VIN to VOUT+1V.
2. Connect the positive terminal of the electronic load to VOUT and negative terminal to GND.
3. For Enable, place a jumper at J1 to "High" position to connect EN pin to enable IC. Jump to "Low" position to disable IC.
4. The evaluation board should now power up with a 3.3V output voltage.
5. Check for the proper output voltage at the output terminals VOUT and GND. Measurement can also be done with a multimeter with the positive and negative leads between VOUT and GND.

Evaluation Board Schematic

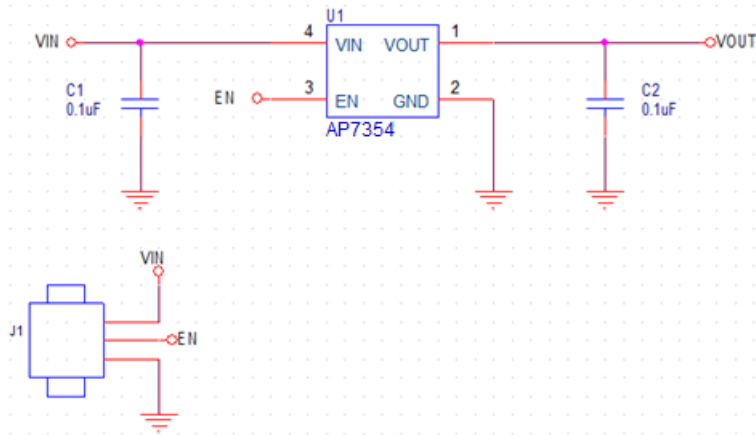

PCB Layout

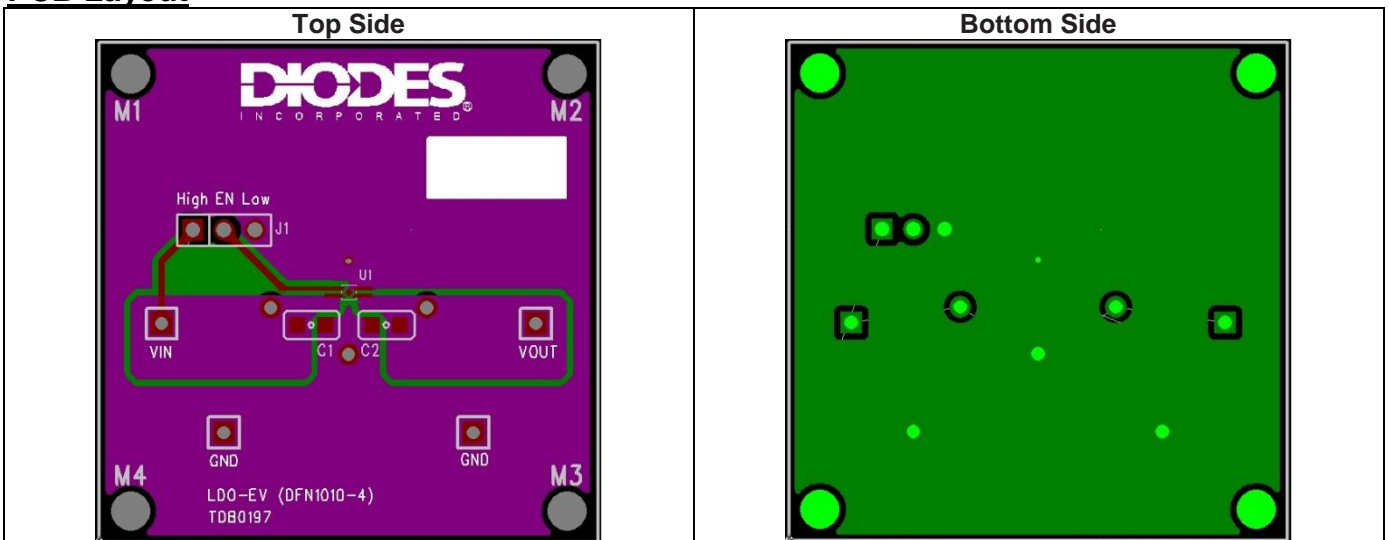

This application note contains new product information. Diodes, Inc. reserves the right to modify the product specification without notice. No liability is assumed as a result of the use of this product. No rights under any patent accompany the sale of the product.

Application Note

AP7354D Application Information and Demo Board User Guide

Bill of Materials

Component Location	Qty	Specification	Mark	Maker Part No.	Size
C1	1	Cap MLCC 0.1uF/50V/X7R	YAGEO	CC0805KRX7R9BB104	0805
C2	1	Cap MLCC 0.1uF/50V/X7R	YAGEO	CC0805KRX7R9BB104	0805
J1	1	0.1"*3 Header 1 and Jumper			5mm X 2.5mm
VIN VOUT GND	4	Test pin			2.2mm X 1.35mm
U1	1	LDO	Diodes Inc	AP7354D-33FS4-7	DFN1010
PCB	1	LDO-EV (DFN1010-4)	Diodes Inc.	TDB0197	40mmX40mm

Vendors of peripheral components

Suggested Capacitors :

Vendor	Capacitance	Type	Series
YAGEO	Cap MLCC 0.1uF/50V/X7R	SMD	CC0805KRX7R9BB104

Application Note

AP7354D Application Information and Demo Board User Guide

IMPORTANT NOTICE

DIODES INCORPORATED MAKES NO WARRANTY OF ANY KIND, EXPRESS OR IMPLIED, WITH REGARDS TO THIS DOCUMENT, INCLUDING, BUT NOT LIMITED TO, THE IMPLIED WARRANTIES OF MERCHANTABILITY AND FITNESS FOR A PARTICULAR PURPOSE (AND THEIR EQUIVALENTS UNDER THE LAWS OF ANY JURISDICTION).

Diodes Incorporated and its subsidiaries reserve the right to make modifications, enhancements, improvements, corrections or other changes without further notice to this document and any product described herein. Diodes Incorporated does not assume any liability arising out of the application or use of this document or any product described herein; neither does Diodes Incorporated convey any license under its patent or trademark rights, nor the rights of others. Any Customer or user of this document or products described herein in such applications shall assume all risks of such use and will agree to hold Diodes Incorporated and all the companies whose products are represented on Diodes Incorporated website, harmless against all damages.

Diodes Incorporated does not warrant or accept any liability whatsoever in respect of any products purchased through unauthorized sales channel.

Should Customers purchase or use Diodes Incorporated products for any unintended or unauthorized application, Customers shall indemnify and hold Diodes Incorporated and its representatives harmless against all claims, damages, expenses, and attorney fees arising out of, directly or indirectly, any claim of personal injury or death associated with such unintended or unauthorized application.

Products described herein may be covered by one or more United States, international or foreign patents pending. Product names and markings noted herein may also be covered by one or more United States, international or foreign trademarks.

This document is written in English but may be translated into multiple languages for reference. Only the English version of this document is the final and determinative format released by Diodes Incorporated.

LIFE SUPPORT

Diodes Incorporated products are specifically not authorized for use as critical components in life support devices or systems without the express written approval of the Chief Executive Officer of Diodes Incorporated. As used herein:

A. Life support devices or systems are devices or systems which:

1. are intended to implant into the body, or
2. support or sustain life and whose failure to perform when properly used in accordance with instructions for use provided in the labeling can be reasonably expected to result in significant injury to the user.

B. A critical component is any component in a life support device or system whose failure to perform can be reasonably expected to cause the failure of the life support device or to affect its safety or effectiveness.

Customers represent that they have all necessary expertise in the safety and regulatory ramifications of their life support devices or systems, and acknowledge and agree that they are solely responsible for all legal, regulatory and safety-related requirements concerning their products and any use of Diodes Incorporated products in such safety-critical, life support devices or systems, notwithstanding any devices- or systems-related information or support that may be provided by Diodes Incorporated. Further, Customers must fully indemnify Diodes Incorporated and its representatives against any damages arising out of the use of Diodes Incorporated products in such safety-critical, life support devices or systems.

Copyright © 2020, Diodes Incorporated

www.diodes.com