

## ZXLD381EV1 USER GUIDE

### Description

The ZXLD381 is a single or multi cell LED driver designed for applications requiring step-up voltage conversion from a very low input voltage and on/off enable control. The IC generates constant current pulses that are ideal for driving single or multiple LEDs over a wide range of operating voltages.

The ZXLD381 uses a PFM control technique to drive an internal switching transistor which exhibits a low saturation resistance. This ensures high efficiency, even for input voltages as low as 1.0V.

The IC can start up under full load and operates down to an input voltage of below 0.9V.

The ZXLD381 is offered in the space saving SOT23-3 package or in die form, offering an excellent cost versus performance solution for single cell LED driving applications.

### Features

- 85% Efficiency
- User adjustable output current
- Single cell operation (0.9V minimum)
- Low saturation voltage switching transistor
- SOT23-3 package
- Available also in Die form
- Simple Application circuit

### Applications

- LED flashlights and torches
- LED backlights
- White LED driver

### Ordering information

<b>ORDER NUMBER</b>
ZXLD381EV1

Please note evaluation boards are subject to availability and qualified leads.

### Typical application circuit

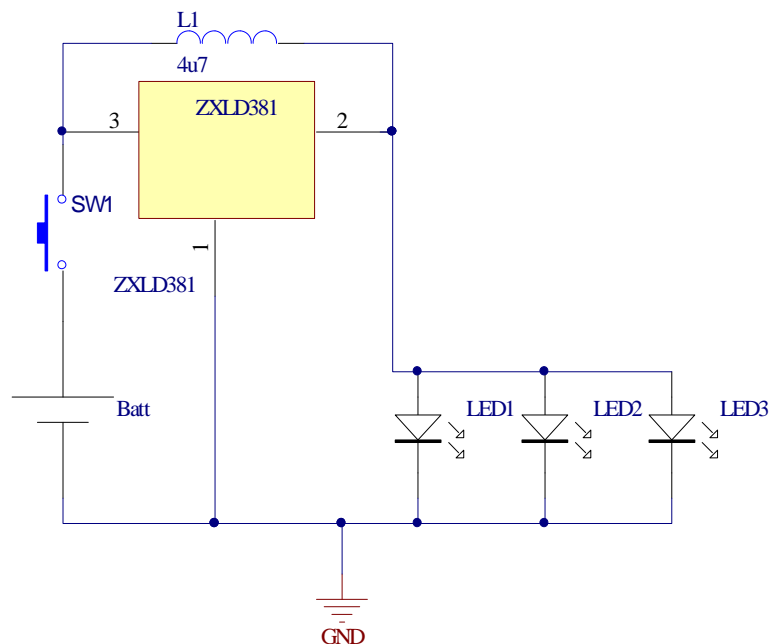

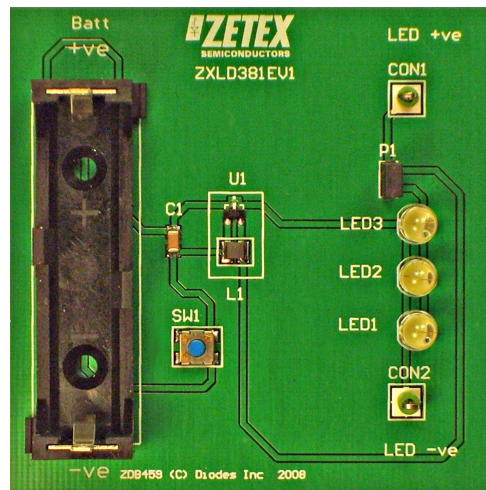

### Reference design

ZXLD381EV1 evaluation board is designed to drive up to 3 white LEDs in parallel. The target application is single cell flashlights and torches.

This board is designed to accept a single AAA cell as the voltage source. Please note that the board does not have reverse polarity protection, so the battery must be fitted correctly.

The circuit is switched on using the momentary push button and goes off when the button is released.

The design demonstrates the simplicity possible with this device: the capacitor C1 may be omitted if the battery is close to the device but is needed otherwise.

The evaluation board is fitted with three T1¼ white LEDs, and to use these, the jumper P1 must be fitted. External LEDs may be connected via CON1 and CON2, marked LED +ve and LED -ve respectively. In this case the jumper must be removed.

For other reference designs or further applications information please refer to the ZXLD381 datasheet.

### Schematic diagram

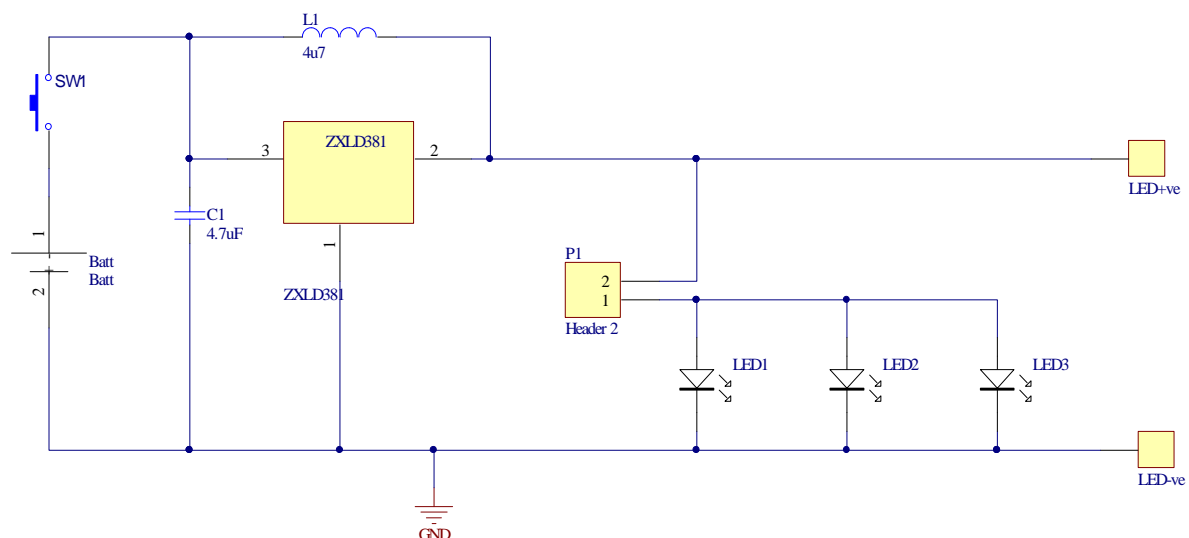

Components list

Ref	Value	Package	Part Number	Manufacturer	Contact Details
U1	LED Driver	SOT23-3	ZXLD381FHTA	Zetex	<a href="http://www.zetex.com">www.zetex.com</a>
L1	4.7uH	ME3220	ME3220-472MLB	Coilcraft	<a href="http://www.coilcraft.com">www.coilcraft.com</a>
C1	4.7uF 25V X7R		C1206C475K3RAC	Kemet	<a href="http://www.kemet.com">www.kemet.com</a>
LED1,2,3	5mm White LED		10000mcd@30mA	(generic)	

Performance graphs

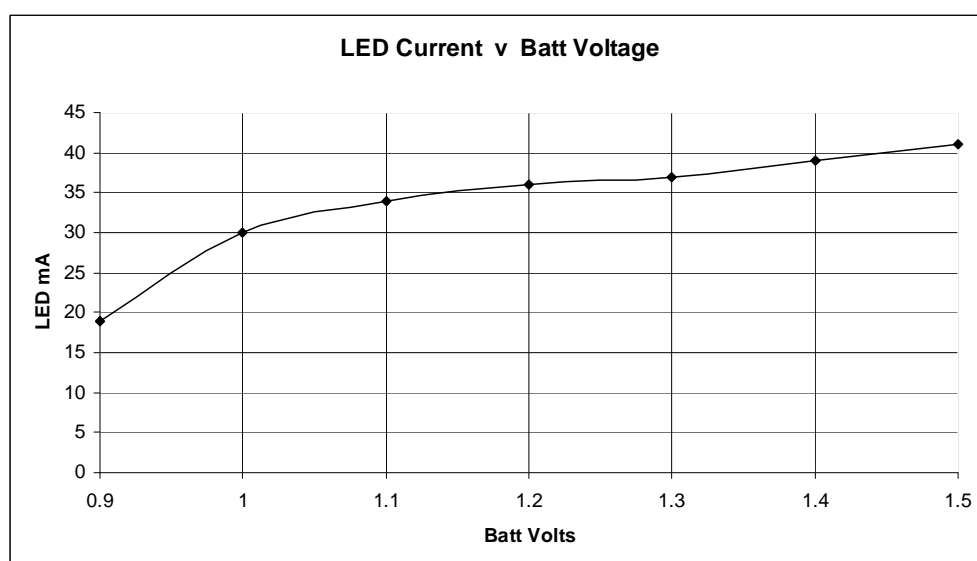
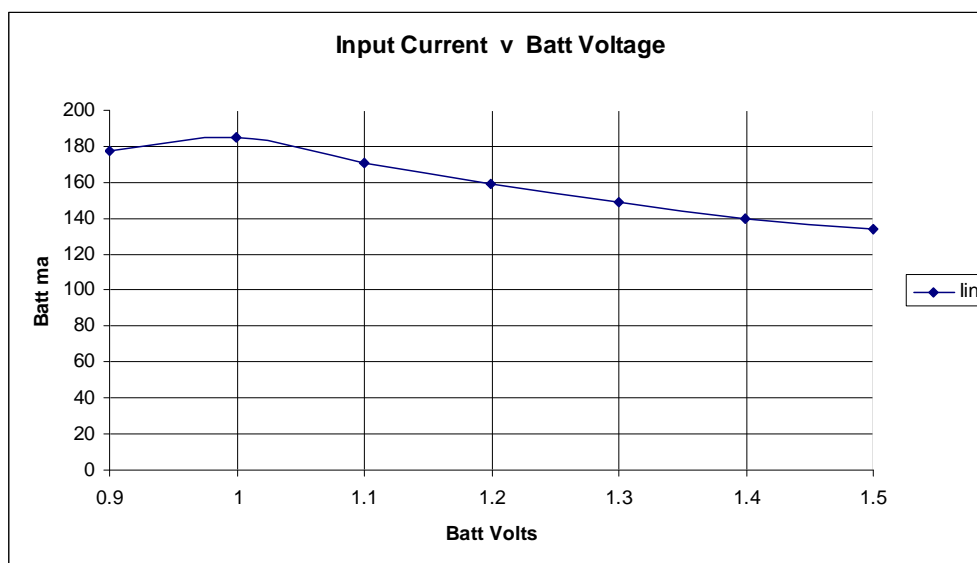

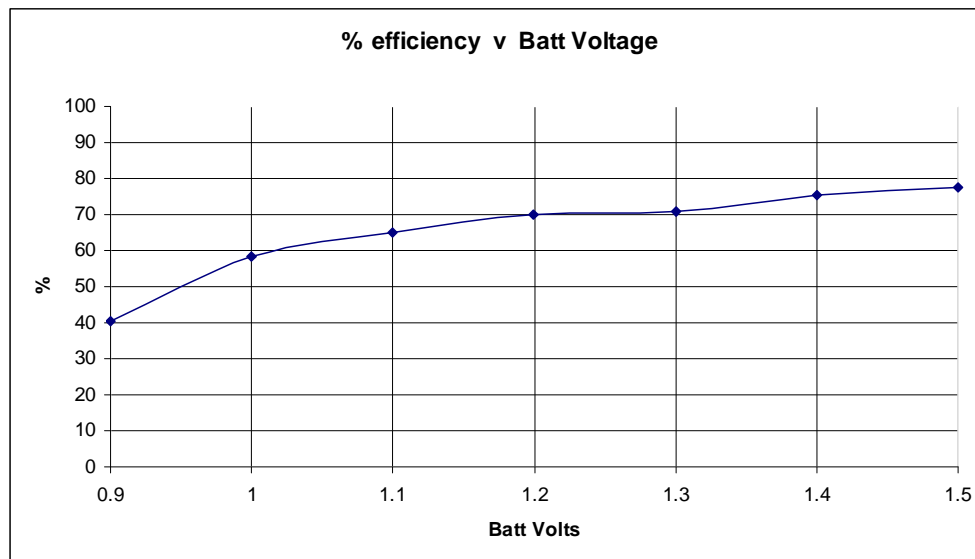

## ZXLD381EV1 operation

### Component layout diagram

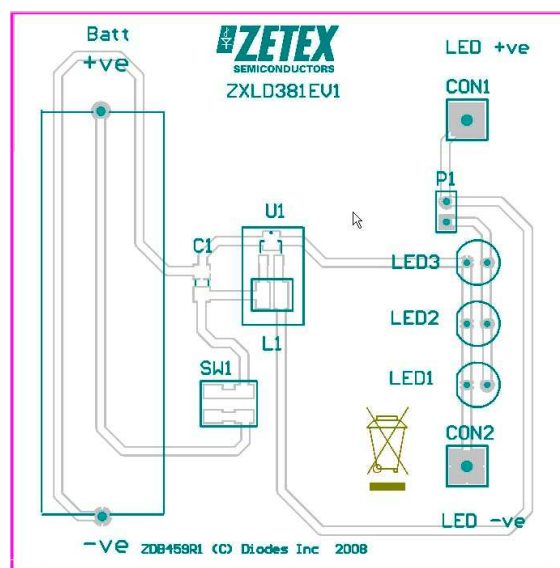

### ZXLD381EV1 set-up and test

1. Preset the PSU to 1.5V with a current limit of around 200mA.
2. Close the link P1.
3. Connect Batt +ve and Batt -ve to the positive and zero volts respectively, of a battery or power supply. Ensure that the connections are made correctly, as the board is not reverse polarity protected.
4. Turn on the PSU.
5. The LEDs should illuminate.
6. The input current should measure between 120mA - 160mA.
7. Turn off the PSU

### Layout considerations

PCB tracks should be kept as short as possible to minimize ground bounce. It is particularly important to mount the coil and the input/output capacitors close to the device to minimize parasitic resistance and inductance, which will degrade efficiency.

**Intentionally blank**

Intentionally blank

Intentionally blank

**IMPORTANT NOTICE**

DIODES INCORPORATED MAKES NO WARRANTY OF ANY KIND, EXPRESS OR IMPLIED, WITH REGARD TO THIS DOCUMENT, INCLUDING, BUT NOT LIMITED TO, THE IMPLIED WARRANTIES OF MERCHANTABILITY AND FITNESS FOR A PARTICULAR PURPOSE (AND THEIR EQUIVALENTS UNDER THE LAWS OF ANY JURISDICTION).

Diodes Incorporated and its subsidiaries reserve the right to make modifications, enhancements, improvements, corrections or other changes without further notice to this document and any product described herein. Diodes Incorporated does not assume any liability arising out of the application or use of this document or any product described herein; neither does Diodes Incorporated convey any license under its patent or trademark rights, nor the rights of others. Any Customer or user of this document or products described herein in such applications shall assume all risks of such use and will agree to hold Diodes Incorporated and all the companies whose products are represented on Diodes Incorporated website, harmless against all damages.

Diodes Incorporated does not warrant or accept any liability whatsoever in respect of any products purchased through unauthorized sales channels. Should Customers purchase or use Diodes Incorporated products for any unintended or unauthorized application, Customers shall indemnify and hold Diodes Incorporated and its representatives harmless against all claims, damages, expenses, and attorney fees arising out of, directly or indirectly, any claim of personal injury or death associated with such unintended or unauthorized application.

Products described herein may be covered by one or more United States, international or foreign patents pending. Product names and markings noted herein may also be covered by one or more United States, international or foreign trademarks.

**LIFE SUPPORT**

Diodes Incorporated products are specifically not authorized for use as critical components in life support devices or systems without the express written approval of the Chief Executive Officer of Diodes Incorporated. As used herein:

A. Life support devices or systems are devices or systems which:

1. are intended to implant into the body, or
2. support or sustain life and whose failure to perform when properly used in accordance with instructions for use provided in the labeling can be reasonably expected to result in significant injury to the user.

B. A critical component is any component in a life support device or system whose failure to perform can be reasonably be expected to cause the failure of the life support device or to affect its safety or effectiveness.

Customers represent that they have all necessary expertise in the safety and regulatory ramifications of their life support devices or systems, and acknowledge and agree that they are solely responsible for all legal, regulatory and safety-related requirements concerning their products and any use of Diodes Incorporated products in such safety-critical, life support devices or systems, notwithstanding any devices- or systems-related information or support that may be provided by Diodes Incorporated. Further, Customers must fully indemnify Diodes Incorporated and its representatives against any damages arising out of the use of Diodes Incorporated products in such safety-critical, life support devices or systems.

Copyright © 2009, Diodes Incorporated

[www.diodes.com](http://www.diodes.com)

**Sales offices****The Americas**

3050 E. Hillcrest Drive  
Westlake Village,  
CA 91362-3154  
Tel: (+1) 805 446 4800  
Fax: (+1) 805 446 4850

**Europe**

Kustermannpark  
Balanstraße 59,  
D-81541 München  
Germany  
Tel: (+49) 894 549 490  
Fax: (+49) 894 549 4949

**Taiwan**

7F, No. 50,  
Min Chuan Road  
Hsin-Tien  
Taipei, Taiwan  
Tel: (+886) 289 146 000  
Fax: (+886) 289 146 639

**Shanghai**

Rm. 606, No.1158  
Changning Road  
Shanghai, China  
Tel: (+86) 215 241 4882  
Fax (+86) 215 241 4891

**Shenzhen**

Room A1103-04,  
ANLIAN Plaza, #4018  
Jintian Road  
Futian CBD,  
Shenzhen, China  
Tel: (+86) 755 882 849 88  
Fax: (+86) 755 882 849 99

**Korea**

6 Floor, Changhwa B/D,  
1005-5 Yeongtong-dong,  
Yeongtong-gu, Suwon-si,  
Gyeonggi-do, Korea 443-813  
Tel: (+82) 312 731 884  
Fax: (+82) 312 731 885